

Intelligent and Robust Multimode System Using I-Button

Sneha Talewar, Nikita Raut, Deeksha Shende, Ruchi Tagde, Nilima Kaikade

Abstract: This project presents the design of multi-access system using arduino and I button. The system performs applications like identification and verification of digital door lock, data security and electronic money transaction, displaced registration details and also gives access to the system. This system becomes very secure and reliable solution to many problems and has hardware simplicity which is specific to one wire technology. The key part of the whole system is ibutton. The ibutton is a computer chip enclosed in a 16mm thick stainless steel can. Because of this unique and durable container, up-to-date information can travel with a person or object anywhere they go. Various components used in this system are I-wire network, ibutton, digital lock, relay, EEPROM memories.

I. Introduction

The i-Button device is a computer chip enclosed in a 16mm thick stainless steel 'can'. The steel i-Button device can be mounted virtually anywhere. It is a small and portable enough to attach to a key fob, ring, watch or other personal items. Because of this unique and durable container up to date information can travel with a person or object anywhere they go. Each i-Button device has a unique and unalterable address. The address can be used as a key or identifier for each i-Button device. i-Button can offer additional features that RFID and barcodes can't. The i-Button is ideal for any application where information needs to travel with person or object.

Using i-Button data server will be secured. i-Button will be given as an input to the i-Button reader. i-Button reader contains two electrical contact areas for i-Buttons: one for simply touching the i-Buttons to the reader for momentary contact and second with an extra push. i-Button reader will be connected to the Arduino Microcontroller which will provide standard form factor that breaks out the function of the microcontroller into a more accessible package for displaying information on LCD screen.

II. Literature Survey

Sr. No.	Name of article/Research paper	Name of author	Name of journal	Year of publication
1.	Security and privacy- a big concern in big data. A case study on tracking and monitoring system.	Tilwani Mashook, Patel Malay.	National conference on latest trends in networking and cyber security.	March 2017
2.	ATM security system using GSM and MEMS.	Swapnali gunjal, poonam shete.	International journal of research in advent technology	February 2017
3.	Digital Door lock System	Ohsung Doh, Ilkyu Ha	Advanced Science and Technology letters.	March 2015

III. Methodology

Tools used:

1. ibutton
2. Arduino Microcontroller
3. ibutton Reader
4. LCD

- **I-Button:**

The ibutton device is a computer chip enclosed in a 16mm thick stainless steel “can”. Because of this unique and durable container ,up to date information can travel with a person or object anywhere they go

- **i-Button Reader:**

Button reader contains two electrical contact area for i-Buttons one for simply touching the i-Buttons to the reader for momentary contact and second with an extra push

- **Arduinio Microcontroller:**

Arduinio Microcontroller will provide standard form factor that breaks out the function of the microcontroller into a more accessible package

- **LCD(Liquid Crystal Display)**

LCD modules are most commonly used in most embedded project, the reason being is itscheap price,availability, and programmer friendly. We will use 16*2 LCD. There are lot of combinations available like 8*1,8*2,10*2,16*1 etc. But the most used one is 16*2 LCD.

IV. Block Diagram

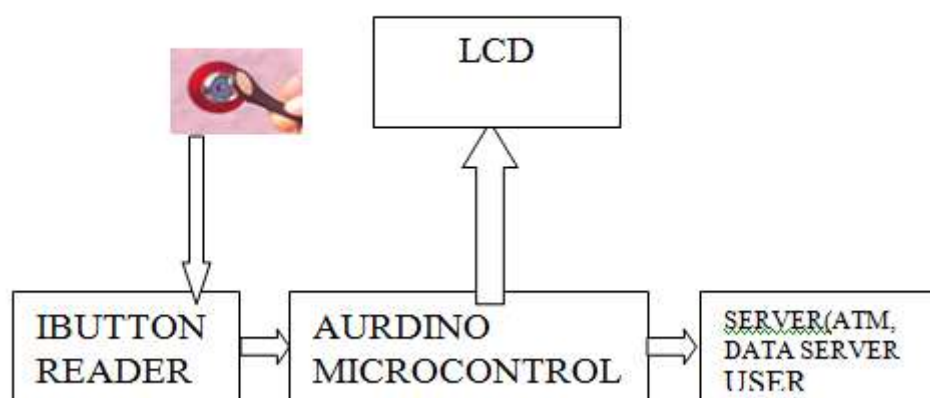

References

- [1]. S.O. Popescu*, A.S.Gontean* and G.Budura**, “BPSK System on Spartan 3E FPGA”, in 10th IEEE Jubilee International Symposium on Applied Machine Intelligence and Informatics January 26-28, 2012 • Herl’any, Slovakia.
- [2]. Secure microcontrollers for smartcards”./acrobat/1065s.pdf. I.F.Akyildiz,W. SU,Y.Sankarasubramaniam “A survey on sensor networks”,IEEE communication magazine.
- [3]. ibutton: A java-powered cryptographic ibutton